

Transmission Charging Methodologies Forum

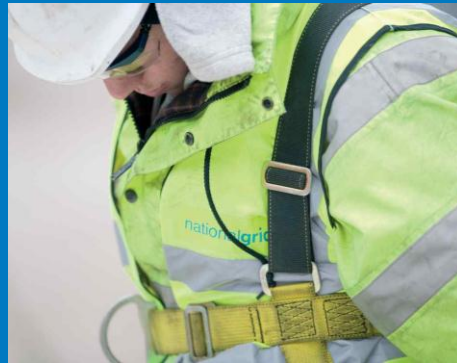

Wednesday 13th May 2015

Introduction and Welcome



Patrick Hynes

Agenda

- 11:00 Introduction – Patrick Hynes
- 11:10 Safety Moment – Juliette Richards
- 11:15 Modifications update – Juliette Richards
- 11:30 TNUoS tariff notice period – Stuart Boyle and Juliette Richards
- 12.30 Generator Focussed Anticipatory Investment – Wayne Mullins
- 12.50 Lunch
- 13.20 BSUoS stability – Nick Pittarello
- 13.50 Exporting GSPs - Andy Wainwright
- 14.10 Triad predictability – Andy Wainwright
- 14.30 CMP213 Judicial Review update – Andy Wainwright
- 14.40 TCMF going forward – Patrick Hynes
- 14.50 AOB and close

Ongoing modification proposals



Juliette Richards

Ongoing modification proposals page 1 of 4

■ **CMP223: Arrangements for Relevant Distributed Generators Under the Enduring Generation User Commitment**

- The Modification was sent back to the CUSC panel and hence has been re-worked. The Workgroup reported to the CUSC panel in March 2015.
- The Code Administrator consultation closed on 1st May 2015.
- Review voting will take place at the May CUSC panel.

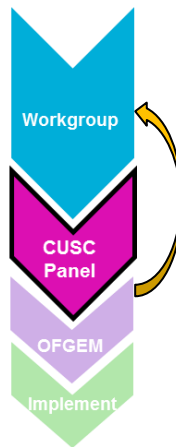

■ **CMP227: Reduce the G:D split of TNUoS charges, for example to 15:85**

- The final Workgroup meeting took place on 23rd April 2015 and the Workgroup will report to the CUSC panel in May.
- Code Administrator consultation will open in June.



Ongoing modification proposals page 2 of 4

- **CMP235 / CMP236: Introduction of a new Relevant Interruption Type / Clarification of when Disconnection Compensation payments can be expected under a Relevant Interruption**
 - The Workgroup reported to the March CUSC panel.
 - The Code Administrator consultation closed on 8th May 2015.
 - The CUSC panel will vote on this modification in May.
- **CMP237: Response Energy Payment for Low Fuel Cost Generation**
 - The final Workgroup meeting took place on 30th April 2015 and the Workgroup will report to the May CUSC panel.
 - Code Administrator consultation to open in June.



Ongoing modification proposals page 3 of 4

■ **CMP238 – Application of Statement of Works Process when a modification application is made**

- An Authority decision was received on 13th March 2015 to implement CMP238. This has now been implemented.

■ **CMP239 – Grandfathering Arrangements for the Small Generator Discount**

- The Workgroup consultation closed on 4th March 2015 and the Workgroup reported to the April CUSC panel.
- The Code Administrator consultation opened on 30th April 2015, and will close on 22nd May 2015.
- The Workgroup will report to the June CUSC panel.



Ongoing modification proposals page 4 of 4

■ **CMP241– TNUoS Demand charges during the implementation of P272**

- This modification was raised to facilitate the implementation of P272 and address the issue with regards to parties being charged NHH and HH in the same year.
- Ofgem have approved this modification and the implementation date was 1st April 2015.
- Further industry communication regarding implementation will be published in June – update at July TCMF.

■ **CMP242– Charging arrangements for interlinked offshore transmission solutions connecting to a single onshore substation**

- This proposal went to the March CUSC panel and has been sent to a Workgroup. It will report back to the panel in September.
- The first Workgroup meeting took place on 1st May 2015.



Possible extension to TNUoS tariff notice period



Stuart Boyle and Juliette Richards

Extension to TNUoS notice period

- The purpose of TNUoS tariffs is to recover the cost of building and maintaining the transmission network from transmission users, in a cost reflective manner.
- Customers have told us that **volatility** of TNUoS tariffs is a problem, particularly for suppliers trying to set their own fixed term tariffs for 1+ years. This leads to a **risk premium** being included in consumer prices.
- Political interest (ECC Select Committee) and DNO precedent (DCP 178) in this area.
- A CUSC modification proposal to extend the TNUoS tariff notice period will be submitted to the May CUSC panel.

Current timeline

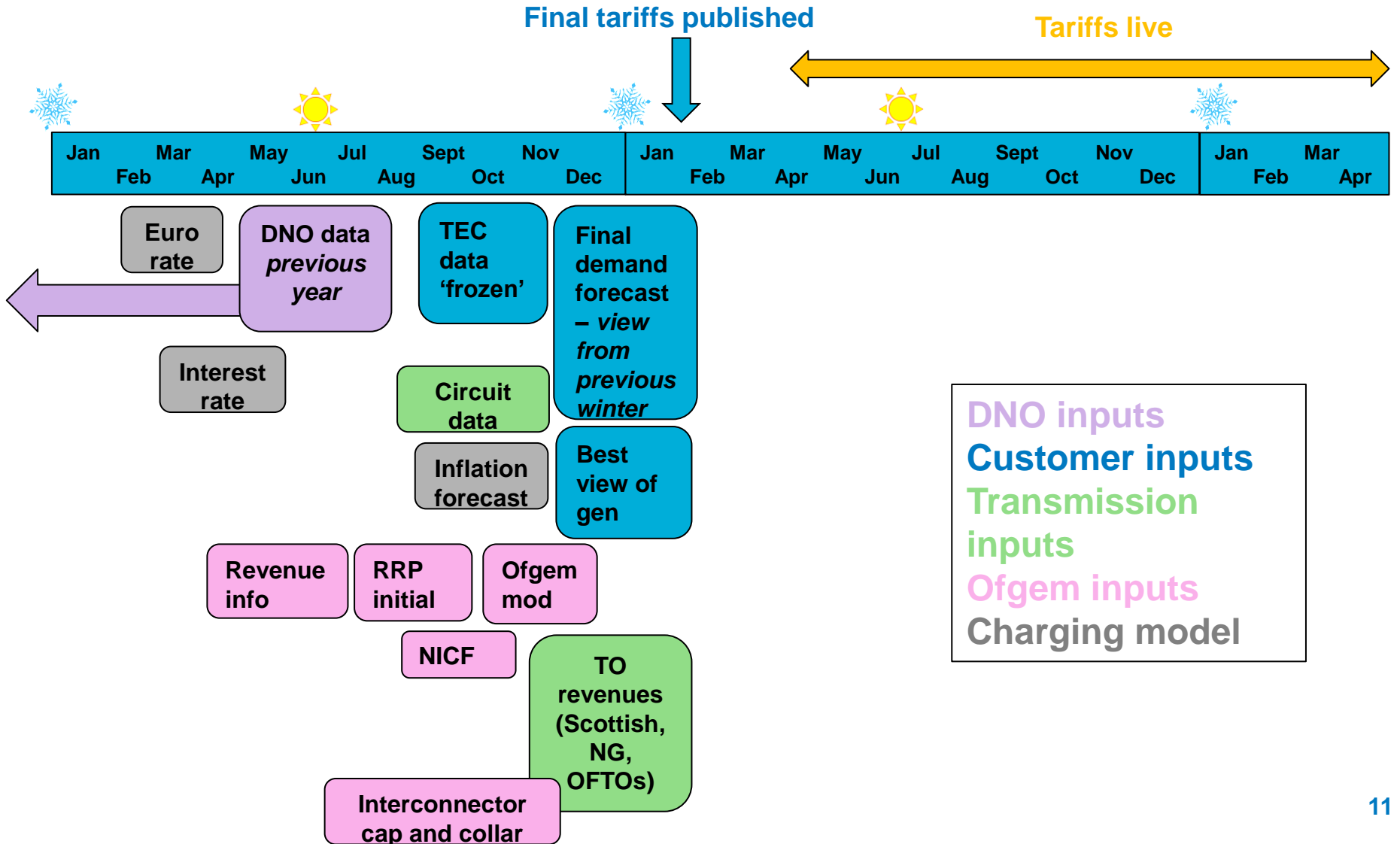

Potential future timeline

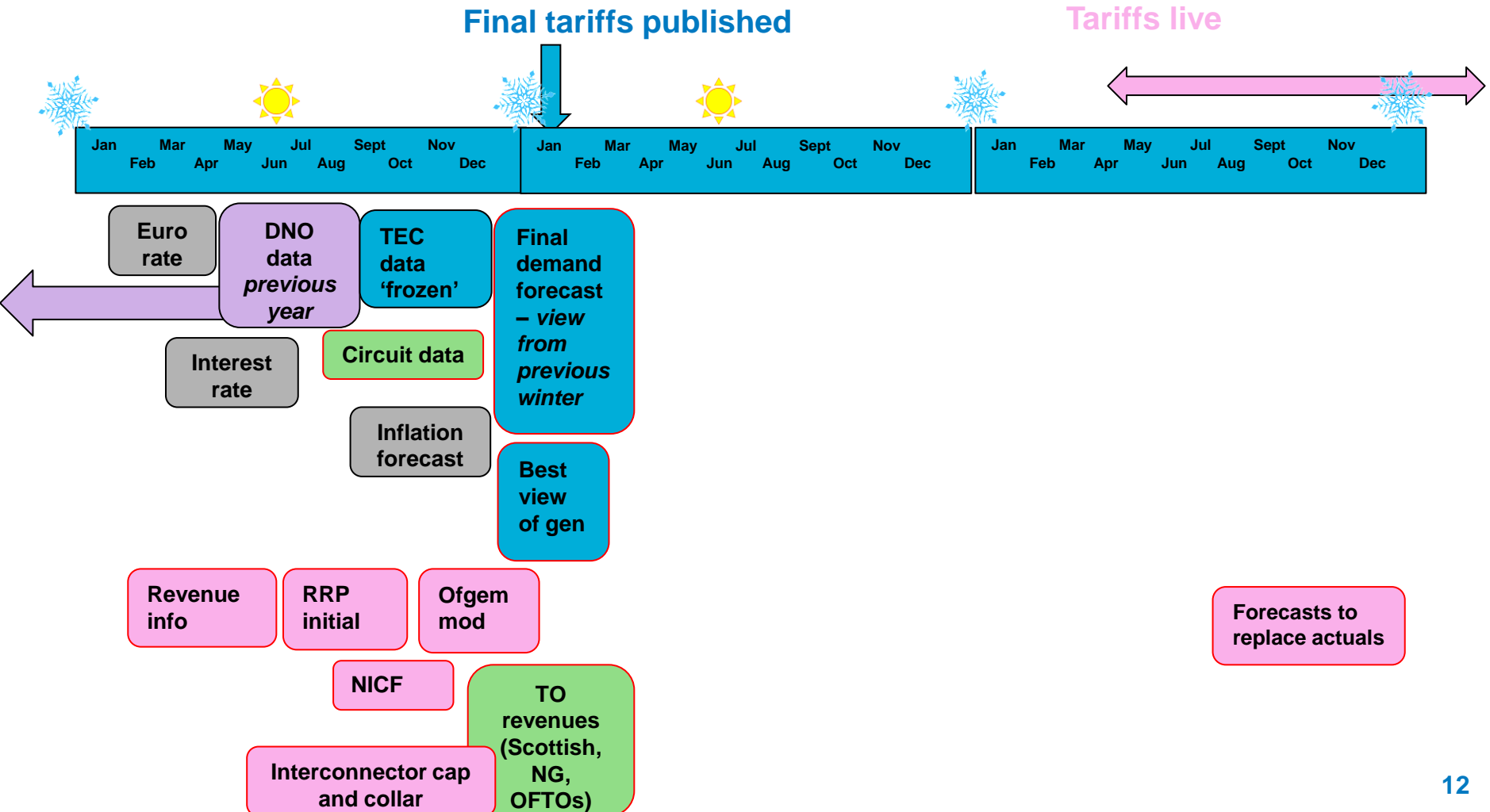

Consequences for tariff setting

- **SO / TO relationships**
- Greater volatility of TO revenues if notice period longer e.g.
 - STC forecasts/notices
 - Strategic Wider Works
 - MOD Determinations
 - Inflation forecasts
 - Pass through & incentive forecasts
 - For offshore – forecast transfer values / dates, post transfer tariff changes
- **Requires licence changes and STC code change**

■ Other Revenues

- Network Innovation Competition
- Interconnector Cap & Collar

■ Charging Base

- Demand volume
- Generation volume and location
- Euro exchange rate

■ Methodology

- 3 years lead time for changes
- Impact on cost reflectivity

■ Price Control

- Under/Over Recovery Incentive
- Cash flow

Potential regulatory changes

NGET licence: special condition 3A - k term and ofgem input for sizes of under / over recovery

NGET price control

CUSC 2.15.2: tariff notice period for users

STC 14-1 – timing of revenue requirement submission from Scottish TOs/OFTOs to NGET

CUSC 11.3 (possibly)
TEC reduction notice period

OFTO licences: k term for under/ over recovery. Payment of availability incentive - timings

Scottish TO licences: special condition 3A - k term and ofgem input for sizes of under / over recovery

Possible principles

Principles:

- Under an extended notice period, the party that has the most influence over an issue should carry the risk (where possible)
- Any signal to influence behaviour needs to be delivered in a way that parties can react to it
- Where risk is transferred party should be compensated for this and not financially penalised

Discussion

- Do you agree with the drivers put forward for an extension to the TNUoS notice period? What are your business time horizons?
- An extended notice period may lead to greater volatility of charges year on year, but with greater certainty of tariffs in the short term – is this an acceptable trade off?
- What level of volatility would be (un)acceptable?
- What are the implications of deferring cost reflectivity?
- Do these sound like the right principles for any future solution?
- Can you think of other issues that might arise for transmission users?

User Commitment for Generator Focused Anticipatory Investment



Wayne Mullins
TCMF – May 2015

Generator Focused Anticipatory Investment

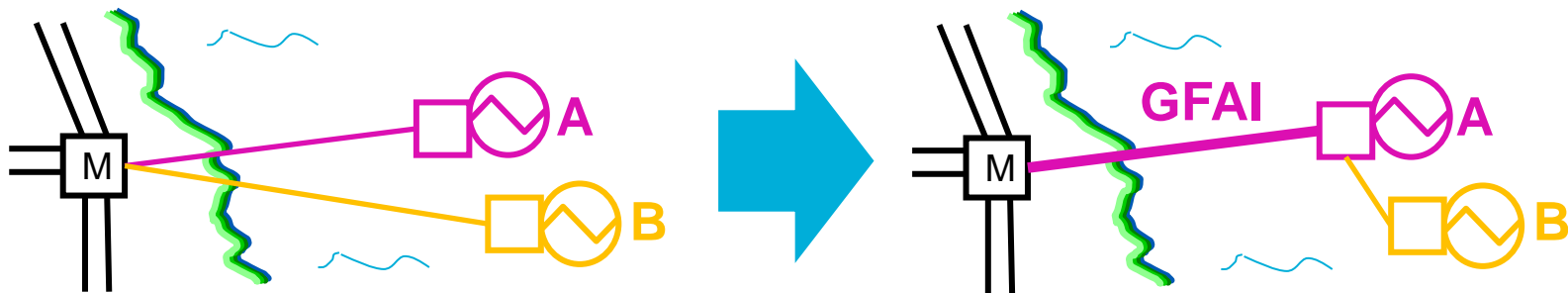

- Coordinated offshore Tx facilitating generation only.
- GFAI can be subject to OFTO or Developer build arrangements.
- Ofgem expectation for adequate User Commitment arrangements to be developed to protect consumers from the undue risk of asset stranding.
- Stakeholder views received via informal consultation and subsequent engagement (TCMF, bilateral meetings, etc.).
- Open letter confirming National Grid thinking (May 2015).

GFAI Scenarios

GFAI Scenario	Funding of GFAI	Risk to Developer A	Risk to Developer B	Risk to Consumers
Single developer – Developer Build	Developer A	Internal	N/A	Investment Stranding (Post-OFTO)
Single developer – OFTO Build	OFTO	Project Delivery*	N/A	Investment Stranding
Multi-developer – Developer Build	Developer A	Investment Stranding	Project Delivery	Investment Stranding
Multi-developer – OFTO Build	OFTO	Project Delivery*	Project Delivery*	Investment Stranding

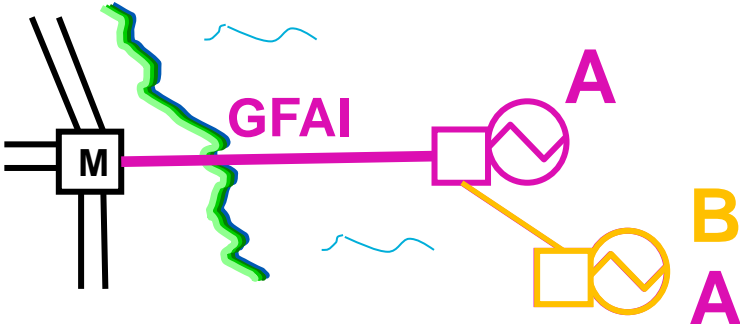

User Commitment for GFAI

- Existing arrangements work for an OFTO build scenario:

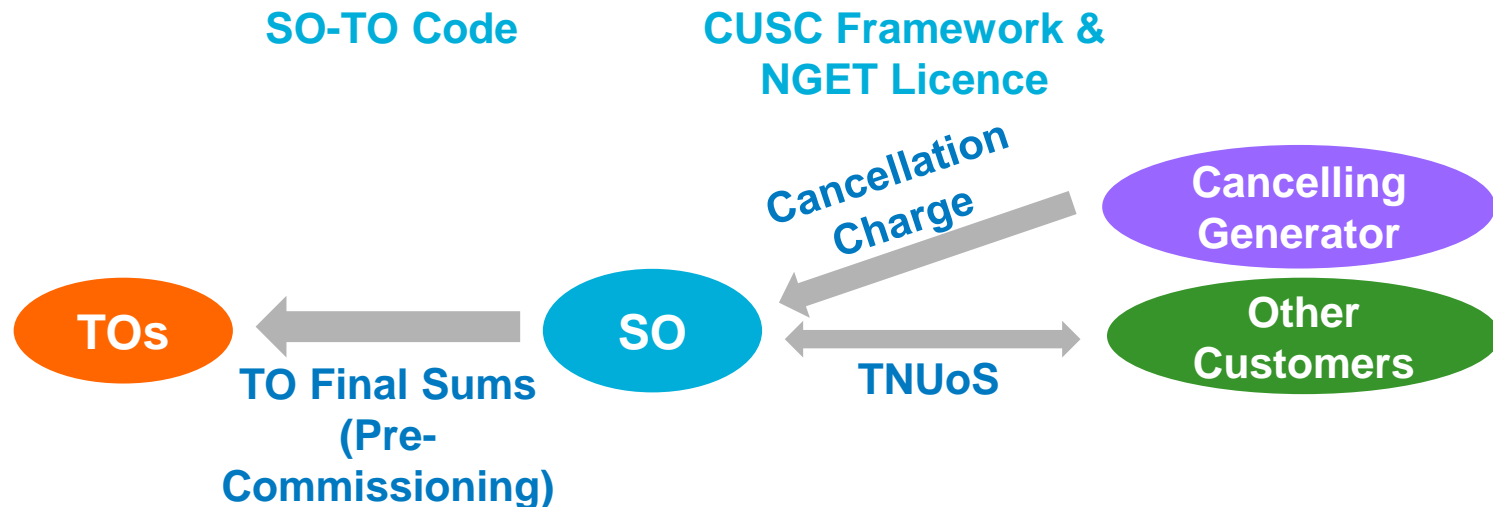

- Developments are required to cover investment stranding under a developer build scenario:
 - Interaction of attributable liability fixing and OFTO tender process (CUSC);
 - Developer recovery of stranded investment (CUSC); and
 - SO pass through of developer costs (Licence)
- No perfect UC solution to project delivery risk under developer build.

National Grid Thinking

- The existing User Commitment arrangements adequately cover OFTO build of GFAI.
- These also work for developer build of GFAI assets for a single developer's projects up to OFTO appointment.
- Some CUSC and Licence changes are required to extend the existing User Commitment arrangements developer build of GFAI for multiple developers' projects.
- However, stakeholder feedback indicates a possible lack of appetite for developer build of GFAI for multiple developers' projects.
- **Changes to be proposed when a clear need is established.**

Lunch



BSUoS Stability Fund – Feedback and Next Steps



Nick Pittarello
15th May 2015

Recap

- At the last TCMF we agreed the problem definition as:
 1. Inefficient generator despatch (ex post pricing)
 2. Potentially high Supplier risk margins
- We discussed ex ante BSUoS pricing
 - This causes a risk transfer from industry to the SO
 - To manage this, an industry funded cash reserve was proposed to fund those instances where actual costs incurred by the SO exceed the ex ante BSUoS price

Ex ante pricing

- For which time period does setting the BSUoS price accrue most benefit?
 - Year, month, week, day, other?
 - How can this be evidenced?
- How long in advance of the fixed period should the price be known?

Funding BSUoS Price Stability

- Who should fund stability?
- In theory there are four possible choices:
 - Payers of BSUoS
 - Transmission Owners (TOs/ OFTOs etc.)
 - SO
 - Hybrid (a combination of the above)

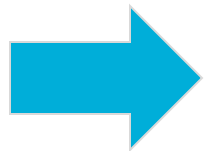

What are the arguments for and against any of these parties funding stability?

Risk Margins

- Is the cost to the consumer of fixing BSUoS less than existing risk margins?
- How would alternative regimes lead to a lower overall cost?
- Is it cheaper for any other party to fund?

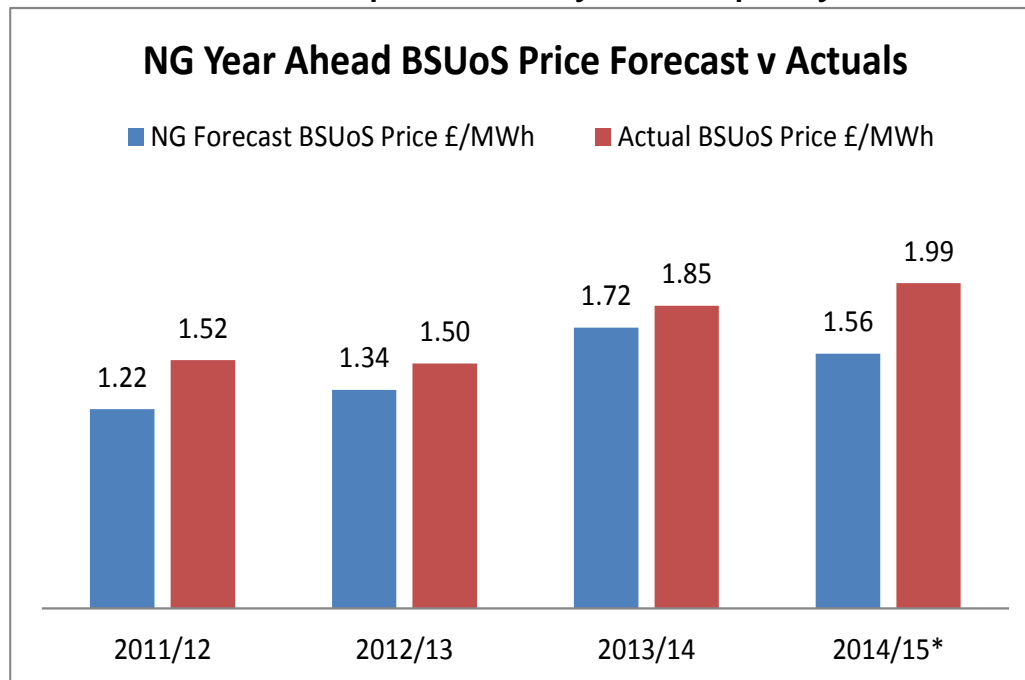

Historically the year ahead forecast has been out by between £0.13/MWh and £0.43/MWh

Supplier risk margins expected to be between £0.25/MWh (25% probability for each year) and £0.50/MWh (worst case?)

Year End outturn ignores possible within year exposures

Cost to the consumer (excluding inefficient despatch) between £80m-£160m per annum (cf £100m stability fund)

High Level BSUoS Description - Today

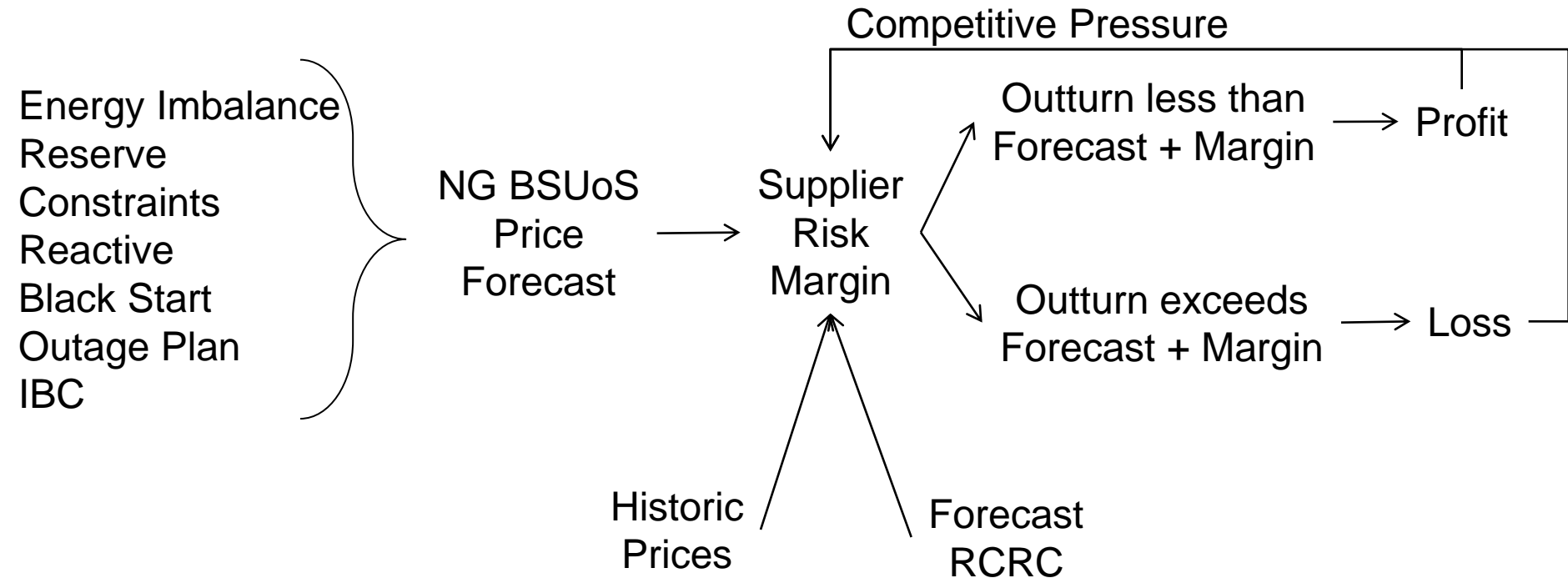

High Level BSUoS Description with Fixed BSUoS

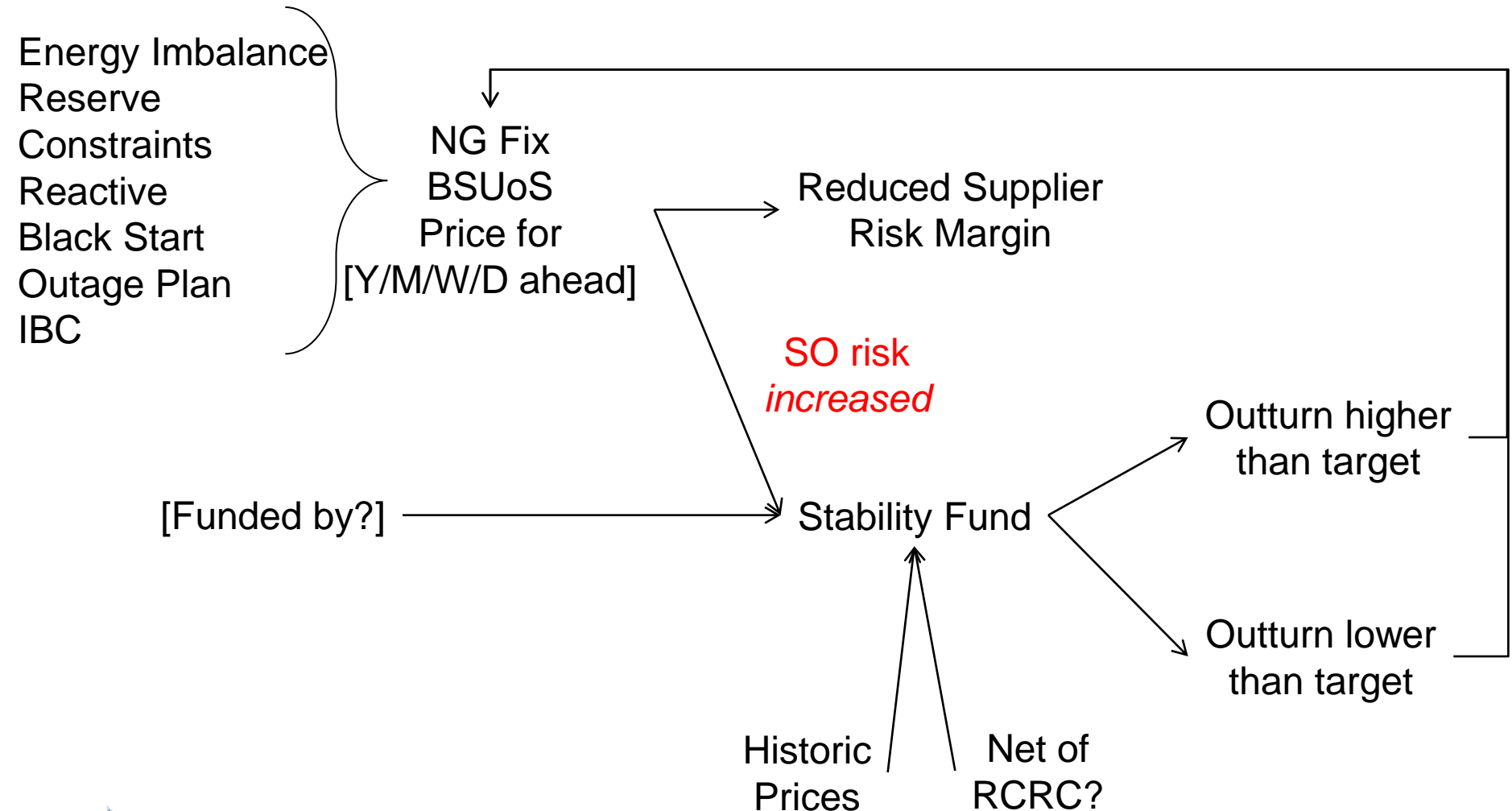

Any views on the netting of RCRC?

Further Questions

- Are there any further concepts that we should explore?

- How can we find the evidence that ex ante BSUoS leads to lower overall costs?
 - What analysis do we need to do?

- How fast should National Grid move on this?

- Any other comments?

Potential options for TNUoS charging arrangements for exporting GSPs - update

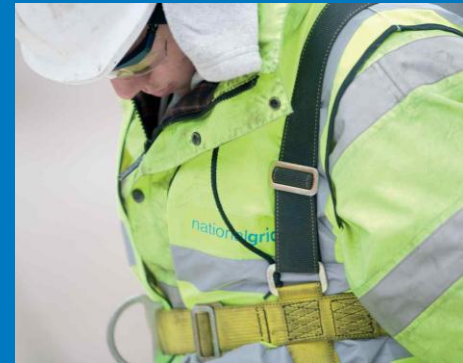

Andy Wainwright

Drivers for this work

**Connection
vs
infrastructure**

**Licence
Requirement**

**Stakeholder
feedback**

**New
GSPs**

**System
operability**

What we've been doing

Discussions with associations

Bilateral Discussions

DNO workshop

Analysis

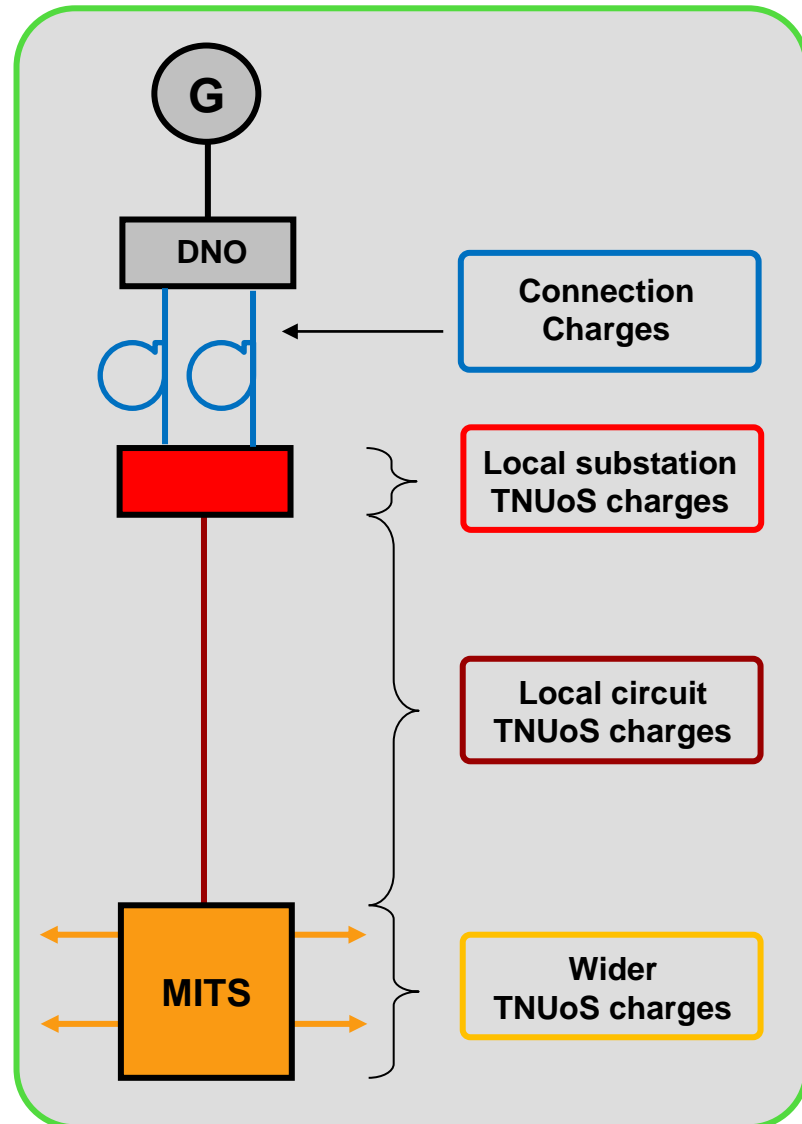

Revised analysis using Elexon data

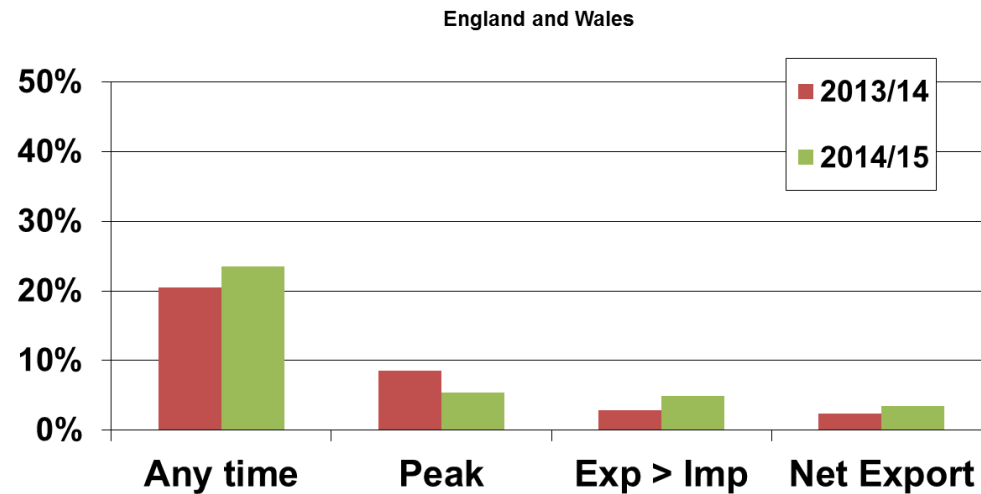
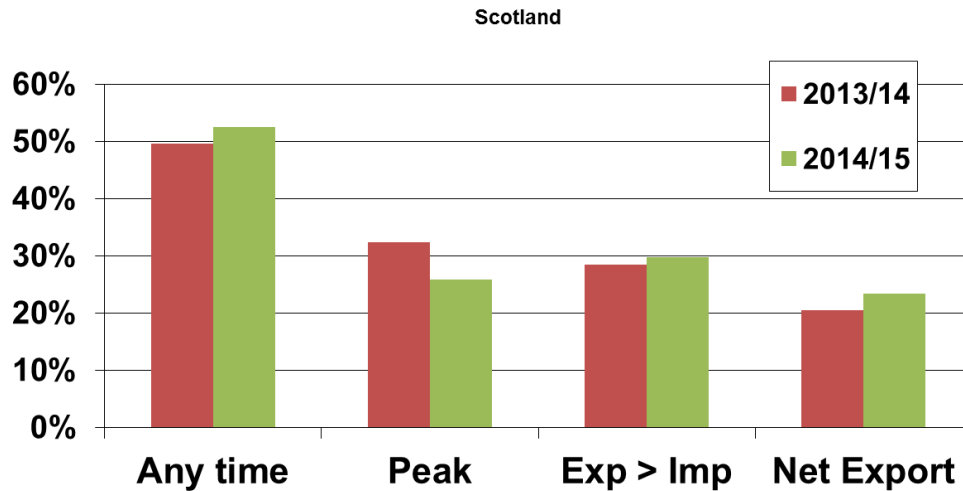

We're interested in your views

**Consultation –
June**

**Bi-lateral
meetings**

**Industry
presentations**

Improving Triad forecasting

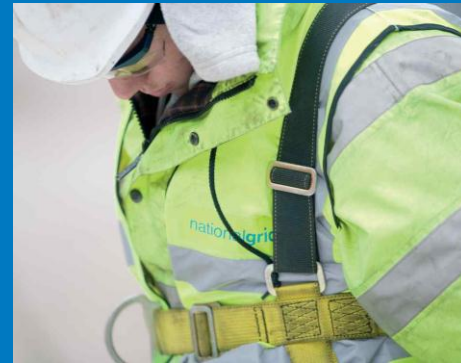

Andy Wainwright

What is the Triad?

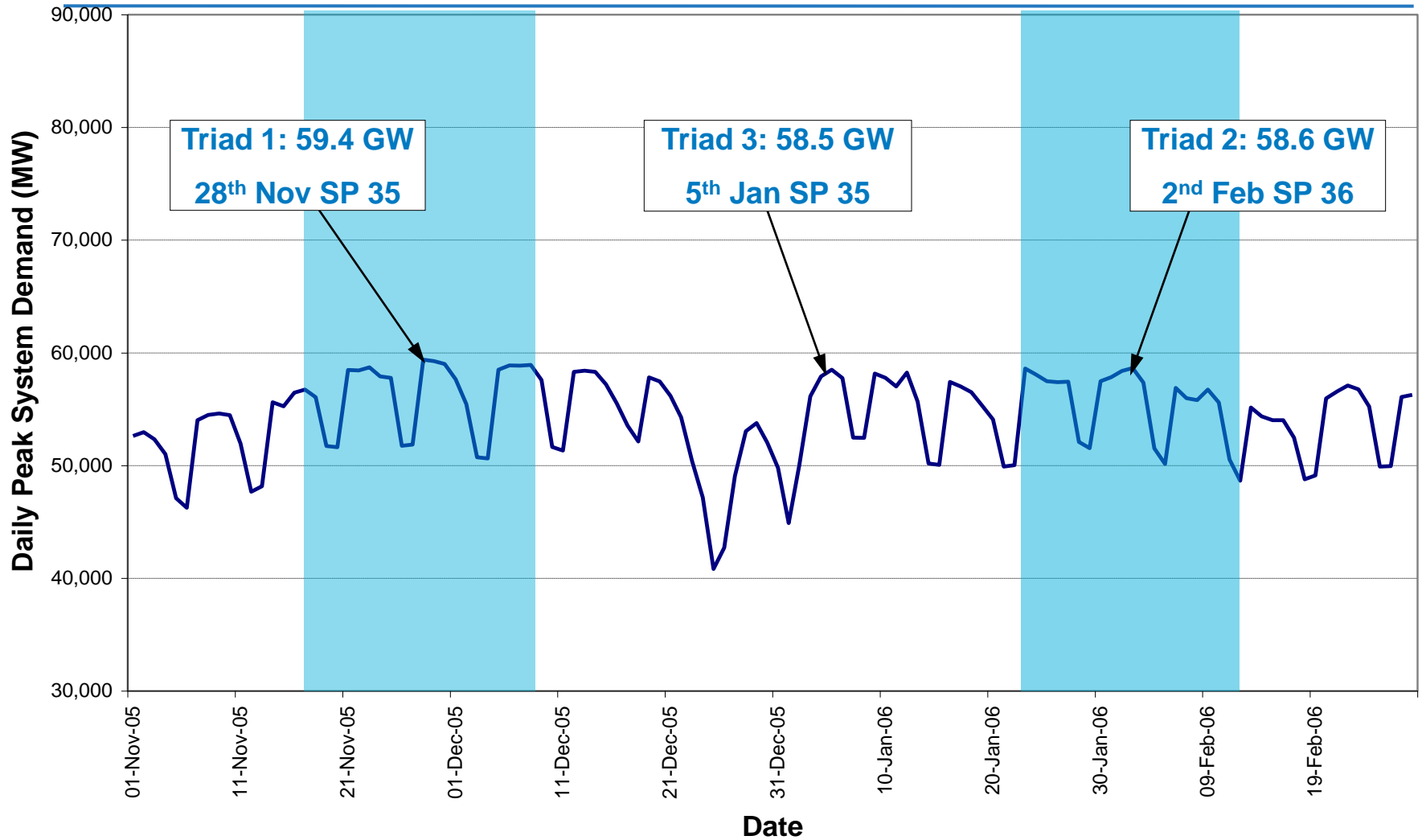

2014/15 Triad

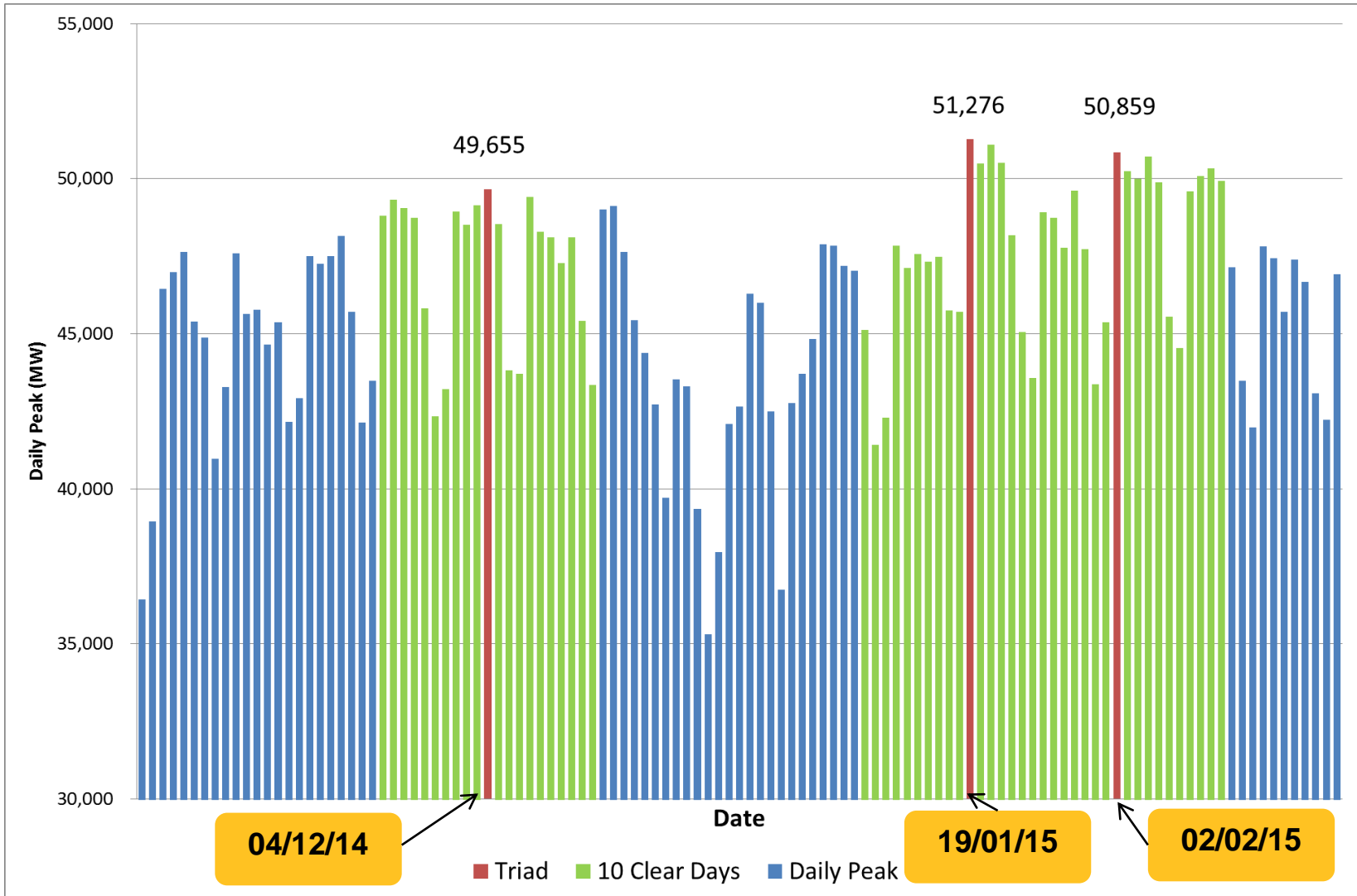

How does it affect TNUoS charges?

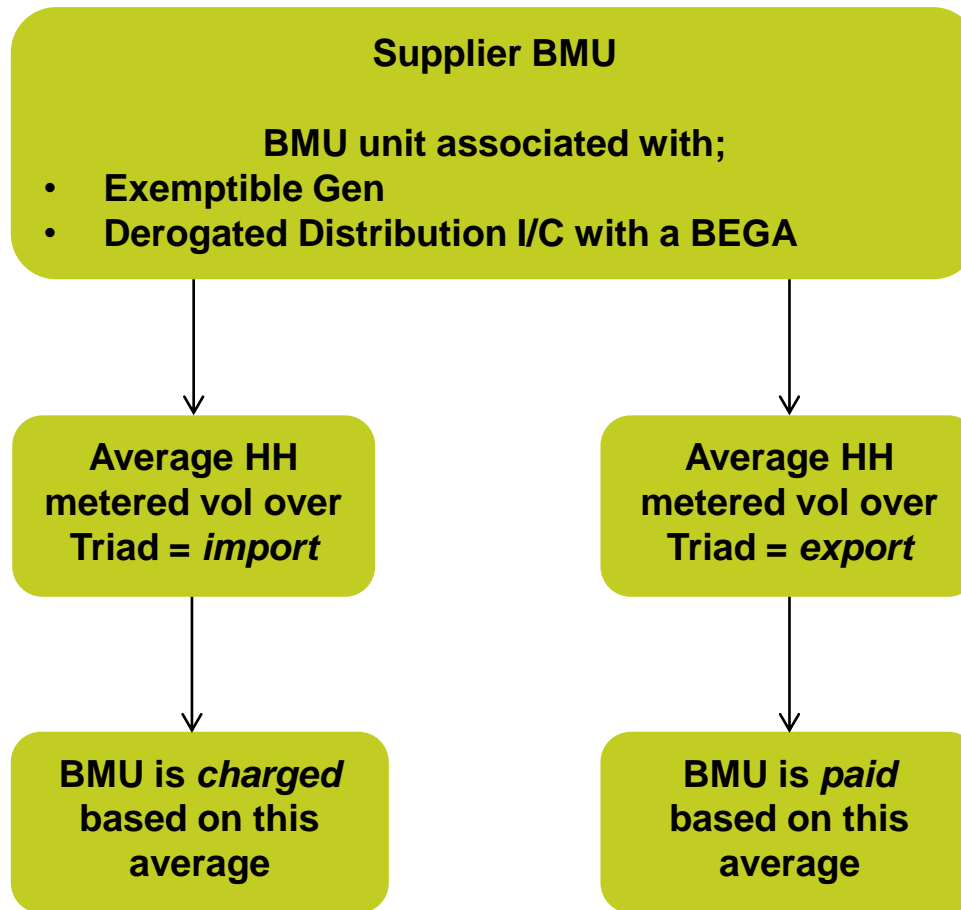

What our customers have told us

Discussions at DSR Provider Group

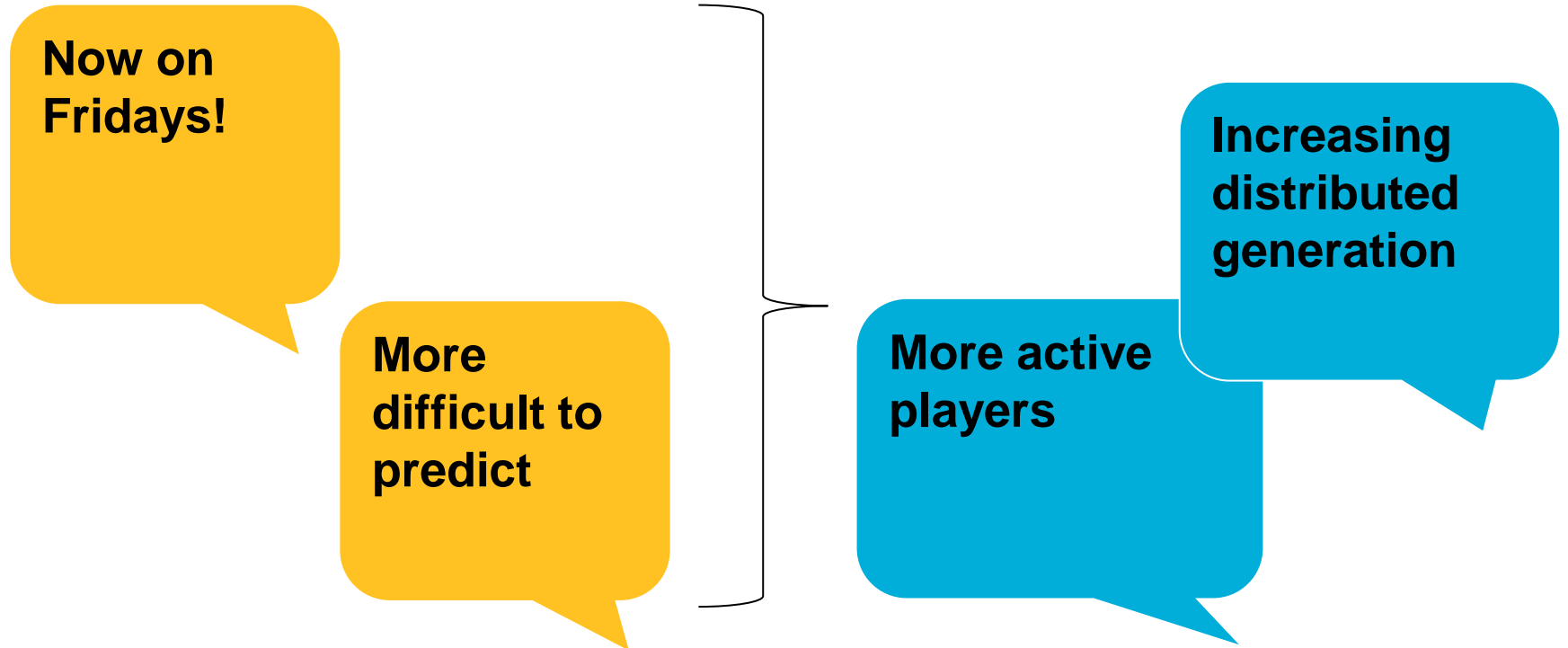

Don't want a detailed review of Triad but incremental change to improve predictability

Your thoughts

- Is this an issue for you?
- What could be done to improve predictability?
 - Review Triad window – is four months reasonable?
 - Is 10 clear working days still relevant?
 - Are number of Triad dates still appropriate?

CMP213 Judicial Review update

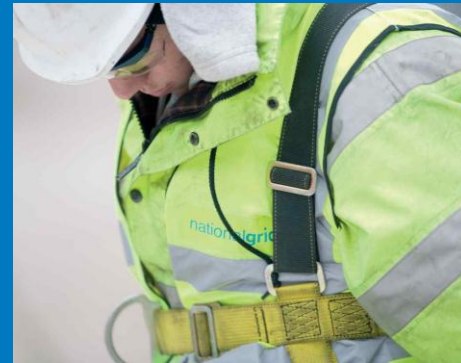

Andy Wainwright

CMP213 Judicial Review update

- Hearing set for 1st and 2nd July 2015
- Judgement possible at hearing, or reserved to be handed down at later date
- Leave to appeal can be sought within 21 days of the judgement being given

Section 15 of the CUSC Implications (CMP240)

- On conclusion of a CMP213 Judicial Review;
 - Provide window for generators to give notice to disconnect / reduce TEC effective at the start of the following Financial Year;
 - 20 business days
 - No Cancellation Charge liability
 - Window referred to as the 'CMP213 Judicial Review Period'

So what does this mean for customers?

- If no appeal;
 - Will email all CUSC parties advising them of the start of the “CMP213 Judicial Review Period” at least 5 working days ahead of its opening.
 - So, for example,
 - If judgement made on Thursday 2nd July we would email CUSC parties on Friday 31st July to advise opening of “CMP213 Judicial Review Period” on Monday 10th August. This would close on Tuesday 8th September (20 business days)
- If appeal will provide update to September TCMF on next steps.

TCMF moving forward



Patrick Hynes

TCMF moving forward

- Currently there is not a forum where people can bring early ideas for development / discussion on general CUSC issues.
- We have discussed changing the form of TCMF with Ofgem, customers and the CUSC Panel.
- In order to avoid Licence and CUSC changes we have agreed with Panel to **form a separate CUSC standing group** to run adjacent to TCMF – to look at all CUSC issues not covered by other standing groups / TCMF.
- The group will not have the power to raise a CUSC mod, but individual parties / NG individually have the power to take issues forward.
- PH will draft ToRs for the CUSC Panel for this new group. It will have open membership, maintain an issues development list and actions, and be chaired by NG.

Any Other Business



Next TCMF

July
8
Wednesday

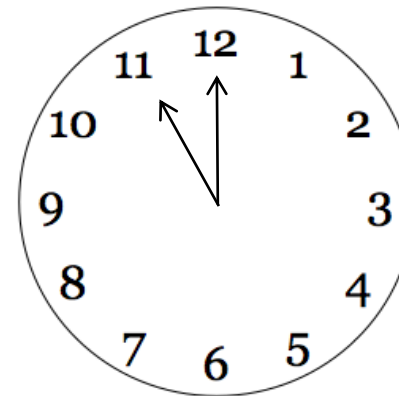

Venue: National Grid House, Warwick

11am start

Future TCMF Dates

September

9

Wednesday

November

11

Wednesday

Venue: National Grid House, Warwick

We value your feedback and comments

If you have any ***questions*** or would like to give us ***feedback*** or share ***ideas***, please email us at:

Cusc.team@nationalgrid.com

Also, from time to time, we may ask you to participate in surveys to help us to improve our forum – *please look out for these requests*

Close

