

Station Name: Novar II

Connection Site/GSP: Alness

Company Name: RWE NPower Renewables

MITs Substations: Beauly and Shin

Derogation Report Ref: 10-DR-018-B0-Rev1

Part 1: Technical Description of Non Compliance [To be completed by the relevant Transmission Owner.]

Relevant Paragraph(s) of NETS Security and Quality of Supply Standard	Cause	Part of System Affected	Initial Conditions		Interim Operational Solution	Long Term Solution, to include brief description of access requirements.	Derogation Expiry Date
			System Intact	Circuit Outage			
NETS SQSS Section 4 Clauses 4.4 – 4.10	<p>Fault outage of Beauly - Shin 132kV double circuit line.</p> <p>Fault outage of Beauly - Dounreay 275kV single circuit line.</p> <p>Fault outage of Mybster - Dounreay 132kV double circuit line.</p> <p>Fault outage of Beauly - Shin 132kV single circuit line.</p>	<p>Overload of Mybster - Dounreay 132kV double circuit line.</p> <p>Overload of Beauly - Shin and Shin – Mybster 132kV double circuit lines.</p> <p>Overload of Beauly -Shin 132kV double circuit line.</p> <p>Overload of remaining Beauly - Alness 132kV single circuit line.</p>	<p>System intact at ACS peak demand</p> <p>System conditions expected to arise in the course of a year</p>	<p>None</p> <p>Typical planned outage pattern</p>	NETSO operational measures in operational timescales in accordance with Section 5 of the NETS SQSS	<p>SHETL to develop and construct the following transmission reinforcements:</p> <ol style="list-style-type: none"> SHETL-RI-005: Dounreay 275kV substation SHETL_RI_006: Beauly – Beauly-Dounreay second 275kV circuit and 132kV QBs SHETL-RI-035: Cambusmore 275kV substation SHETL_RI_036: Beauly – Cambusmore 275kV circuit reconductoring SHETL-RI-037: Alness 275kV substation SHETL-RI-031: Mybster 600MW HVDC link and 132kV substation SHETL-RI-032: Dounreay – Mybster 275kV rebuild <p><i>Completion dates subject to consents and regulatory approval</i></p>	<p>Derogation is sought until completion of listed long-term reinforcement solutions.</p> <p>Derogation triggered by advancing generator connections via connect and manage arrangements</p>

Station Name: Novar II

Connection Site/GSP: Alness

Company Name: RWE NPower Renewables

MITS Substations: Beauty and Shin

Derogation Report Ref: 10-DR-018-B0-Rev1

2011 System diagram

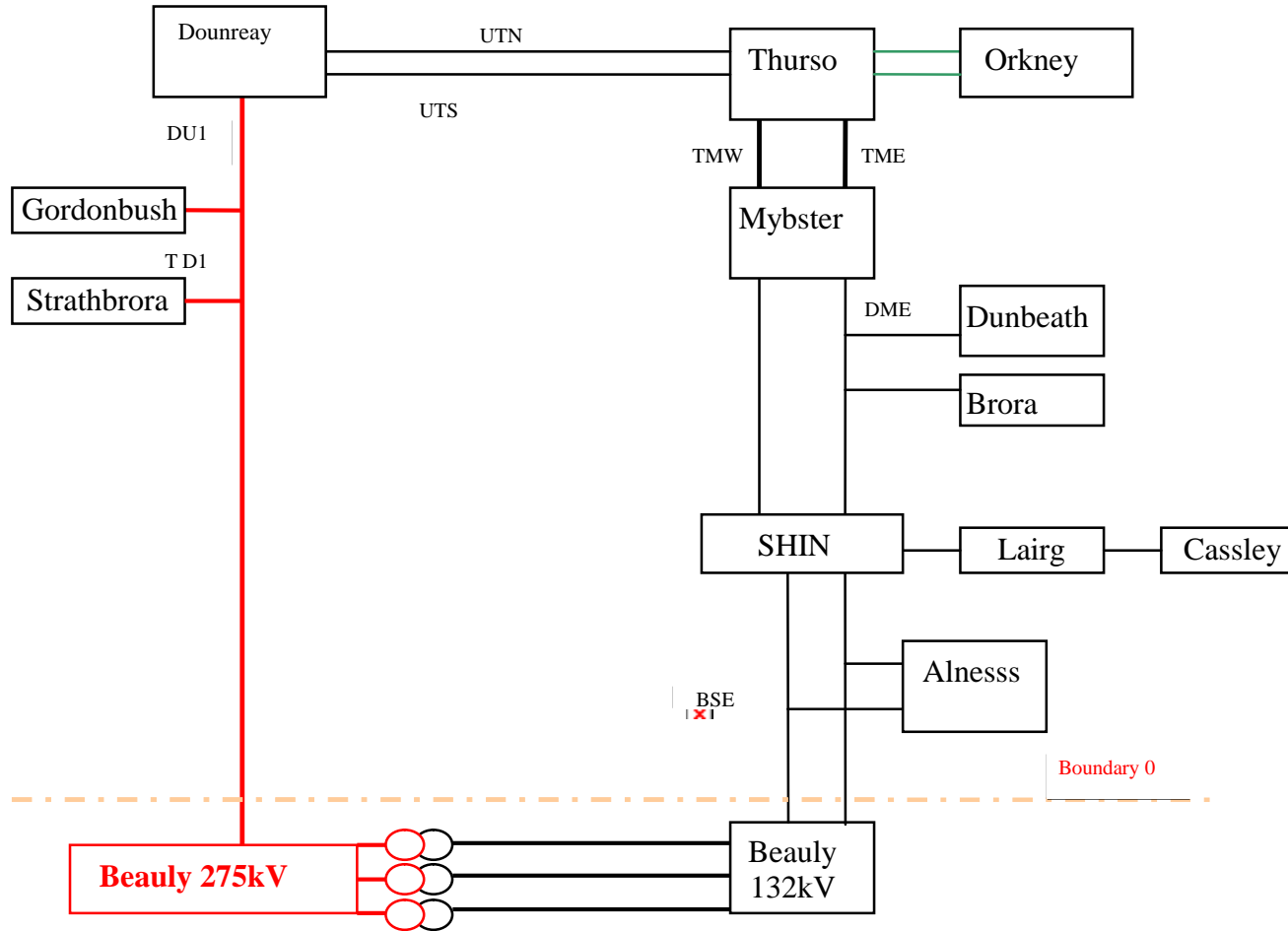

North of Beauty

Station Name: Novar II

Connection Site/GSP: Alness

Company Name: RWE NPower Renewables

MITS Substations: Beaully and Shin

Derogation Report Ref: 10-DR-018-B0-Rev1

Part 2: Expected Consequence of Non -Compliance. *[To be completed by the System Operator, with reference to appropriate Transmission Owner.]*

Value of Carbon Benefit (£k), (including time period over which cost benefit is calculated).	
Summary of proposed System Operator actions to manage non- compliance. <i>To include:</i> <i>pricing assumptions.</i> <i>Description of diversity within the</i> <i>group (not to include reference to</i> <i>particular projects)</i> <i>User agreements for services such</i> <i>as energy management or intertrips.</i> <i>Contribution of project to wider non</i> <i>compliance at boundary level.</i>	
Estimated range of costs to manage non compliance (£k). To include time period over which costs are assessed.	
Description of risk due to network non compliance. e.g. constraint increase due to project delay	